

Maximum Load: 44 Tonnes

Yellow Wheel Chock 250L x 190W x 200H

Product SKU: 6010929

Wheel chocks made entirely from a yellow rubber compound for improved visibility.

These HGV wheel chocks are made entirely out of a yellow rubber compound and are not a black rubber painted yellow which is great for improving the visibility of the chock. They are moulded with an integral handle at the back of the chock to make it easier to lift and use. The 6009684 is recommended for small to medium sized HGV vehicles, it has a hollowed design to improve the weight and cost of the item. Safety notice - Only select the appropriate wheel chock according to the type and size of your vehicle. Wheel chocks should be used in pairs and applied only when the vehicle has come to a complete standstill. It is paramount the end user tests the product and ensures it is suitable for the application requirement.

Colour: Yellow

Material: NR/SBR

Operating temperature range: -15°C to 70°C

Physical Property	Unit	Typical Values
Hardness	ShA	75
Elongation at Break	%	200
Tensile Strength	MPa	4
Weight	KG	6

Although the technical details and recommendations made correspond to the best of our knowledge and experience, all the above information must, in every case, be taken as merely indicative and subject to confirmation after long-term practical application; for this reason, anyone who intends to use Polymax products must ensure beforehand that it is suitable for the envisaged application. In every case, the user alone is fully responsible for any consequences deriving from the use of the product. All sales subject to our standard terms www.polymax.co.uk/sales-terms

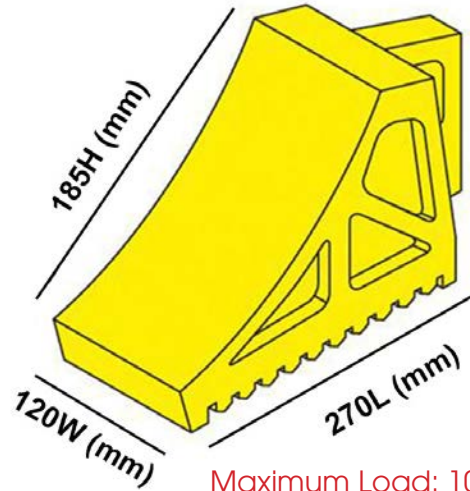

Yellow Wheel Chock 270L x 120W x 185H

Product SKU: 6009684

Wheel chocks made entirely from a yellow rubber compound for improved visibility.

These HGV wheel chocks are made entirely out of a yellow rubber compound and are not a black rubber painted yellow which is great for improving the visibility of the chock. They are moulded with an integral handle at the back of the chock to make it easier to lift and use. The 6009684 is recommended for small to medium sized HGV vehicles, it has a hollowed design to improve the weight and cost of the item. Safety notice - Only select the appropriate wheel chock according to the type and size of your vehicle. Wheel chocks should be used in pairs and applied only when the vehicle has come to a complete standstill. It is paramount the end user tests the product and ensures it is suitable for the application requirement.

Colour: Yellow

Material: NR/SBR

Operating temperature range: -15°C to 70°C

Physical Property	Unit	Typical Values
Hardness	ShA	75
Elongation at Break	%	200
Tensile Strength	MPa	4
Weight	KG	3

Although the technical details and recommendations made correspond to the best of our knowledge and experience, all the above information must, in every case, be taken as merely indicative and subject to confirmation after long-term practical application; for this reason, anyone who intends to use Polymax products must ensure beforehand that it is suitable for the envisaged application. In every case, the user alone is fully responsible for any consequences deriving from the use of the product. All sales subject to our standard terms www.polymax.co.uk/sales-terms